

hygo. MKII

Installation Guide 3.5T Hydraulic Braking System

**Keeping Local trailer manufactures
competitive with EU trailer imports.**

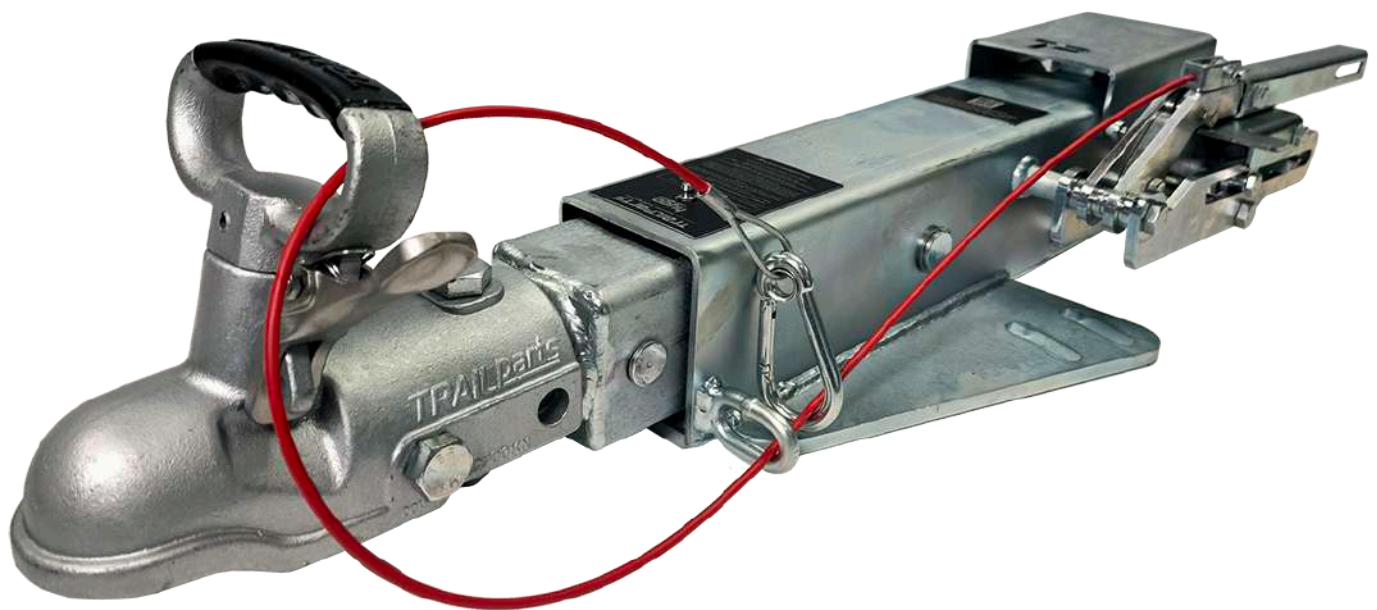

TRAILPARTS™
Innovative Trailer Solutions



We do the business.

Handbrake & Breakaway System

A stand-alone cable brake system provides a parkbrake function that doubles as an emergency brake that activates in the event of a tow vehicle separation.

Wheel Specification

Testing and certification of the Trailparts Hygo system use tyres that are 195mm wide. Wheel diameters between 525mm and 670mm can be used.

Trailparts™ Coupling with 1.7/8" head or our Trailparts™ Autofit for both 1.7/8" and 50mm

We have locally engineered robust hard wearing couplings. These have a damped braking action and breakaway function. We give two cast head options; a 1.7/8" one, and an all-new Trailparts™ Autofit head that can be used on 1.7/8" and 50mm towballs.

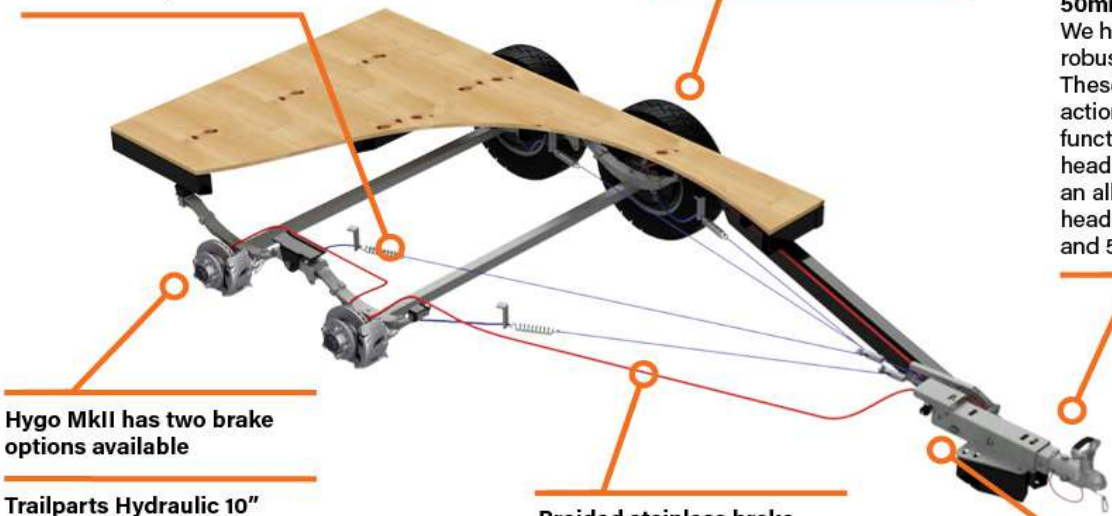

Hygo MkII has two brake options available

Trailparts Hydraulic 10" Drum

These brakes are highly effective while being a very economic brake option

Trailparts Patriot Disc with 230mm Vented Rotor

High performance is available, when these disc brakes are fitted. The excess of performance available means minimal wear, and they are self adjusting. They also have an inbuilt park brake lever function.

Braided stainless brake hose system

Braided stainless brake lines are specified throughout.

Brake hoses are incredibly fast to fit, and can be done with simple tools and nonspecialized labour.

High performance hydraulic brakes

Hygo couplings feature a 1" bore master cylinder fitted with Autoback reversing solenoid. Allowing easy reversing as required by EU laws.

CONTENTS

The Trailparts Hygo MkII is a cost effective, multi-vehicle capable trailer brake system that is suitable for trailers up to 3500kg in New Zealand when installed according to this guide that follows.

Page 3 - 4

Coupling Mounting

Page 5

Hydraulic Line Installation

Page 6

Brake Bleeding

Page 7 - 8

Brake Cable Installation
Hydraulic Drum Brake

Page 9 - 10

Brake Cable Installation
Patriot Disc Brake

Page 11

Coupling Operation

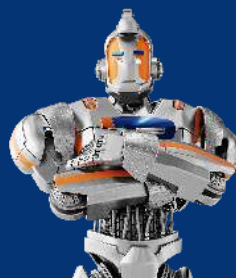

COUPLING MOUNTING

⚠ The coupling is a critical safety item, and one of the mounting options below must be followed completely.

MOUNT OPTION 1 **FOR A-FRAME DRAWBARS**

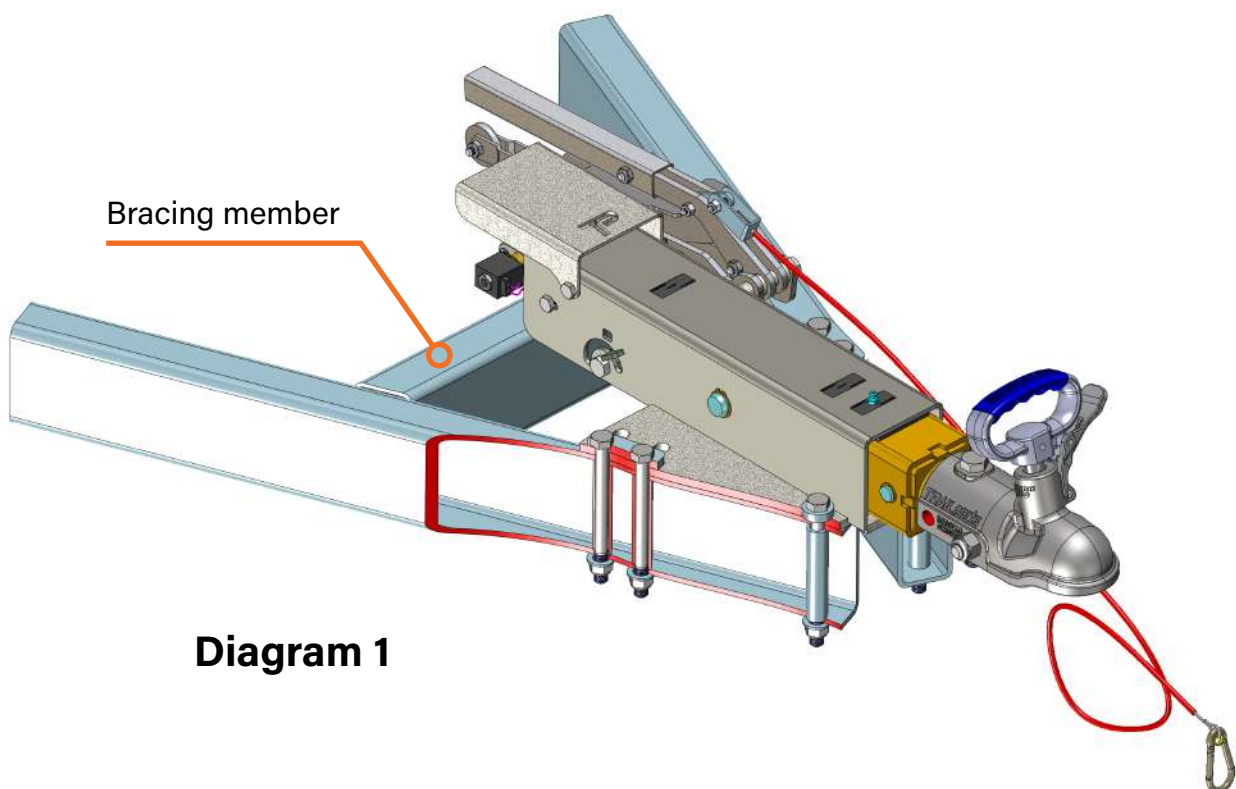

The Hygo MkII coupling can be used as a structural member, and bolted directly to the top of the drawbar as shown in diagram 1 (shown above).

- Drill the hole pattern through the top and bottom of the drawbar. The front hole centres must be at least 25mm from the front edge of the drawbar.
- Bolt through the coupling plate, and through the drawbar section.
- A bracing member must be used between the two drawbar beams. This should be a SHS or RHS profile, and cover the drawbar depth completely. This should be welded somewhere within the coupling length.
- Crush tubes that are a neat ID fit must be used inside the drawbar tube.
- Grade 8.8 or higher M12 bolts must be used in all 6 x mounting holes. These should be torqued to 130Nm.
- Plate washers >6mm must be used under the bolt heads in the four rear slotted coupling mount holes.

NOTE: A welded mounting plate can be added to this mount option if desired.

MOUNT OPTION 2 FOR STRAIGHT DRAWBARS

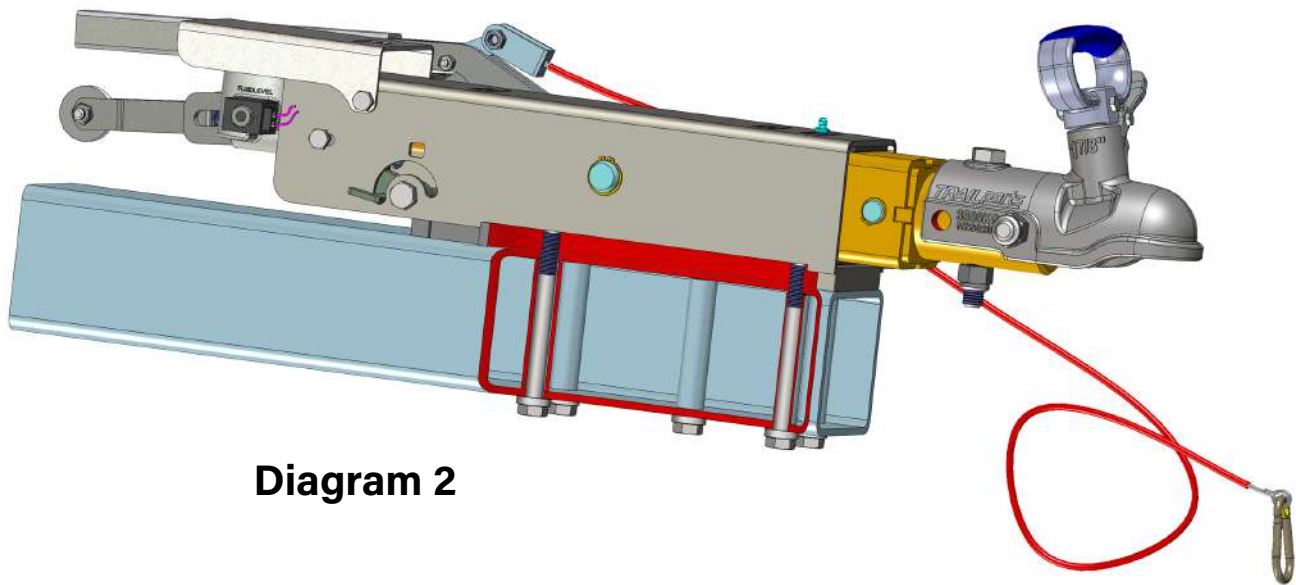

Diagram 2

This guide is where the Hygo MkII coupling is being fitted to a straight drawbar, as shown in diagram 2 (shown above).

- Trailparts will supply a different coupling mount system for this mounting style, where the coupling has a heavy 16mm plate with threaded holes designed to take bolts from underneath. The coupling mount hole pattern is the same as in common cast braked marketplace couplings – 54mm wide x 184mm.
NOTE: It is critical that every mounting step below is followed closely.
NOTE: These instructions relate to 100mm deep drawbars. Fitting to other sizes is permitted, but bolt lengths and considerations about mounting thread engagement need to be considered.
- Drill the hole pattern through the top and bottom of the drawbar. The front hole centres must be 25mm from the front edge of the drawbar.
- In this mount configuration, ½" bolts and crush tubes must be used, as they are the same thread, required to engage the pre-tapped coupling mount holes.
- Assemble the bolts and crush tubes through the drawbar, then thread into the relevant coupling mount hole.
- Tighten the ½" bolts into the coupling using a torque wrench set to 130Nm.

NOTE: Trailparts stock components to facilitate this mounting as follows;

- Laser cut 6mm dual-hole washer plate for rear slotted holes.

NOTE: Trailparts Do NOT stock the required components listed below;

- Crush tubes to suit M12 and ½" UNF bolts and 100mm deep box section.
- Grade 8.8 M12 x 140mm zinc plated bolts and locknuts for mount option 1.
- Grade 10.9 ½" UNF x 4.5" zinc plated bolts for mount option 2 applications.

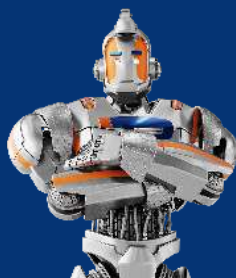

HYDRAULIC LINES INSTALLATION

On Trailparts axles, drum brakes will be pre-adjusted and ready for installation of brakelines.

The Hygo MkII brake system is designed to use Banjo Banjo stainless steel braided lines throughout, although other fixed lines such as steel and cupro-nickel are acceptable alternatives. Banjo Banjo braided lines are resistant to damage, and are fast and easy to install.

Lines can be run inside chassis members if desired. If mounted externally, always fix the lines firmly to the trailer chassis using sleeved stainless or nylon P-clips.

MOUNTING BRAKE LINES

1. Trailparts recommend the line routing as shown in diagram below

- Avoid unnecessary loops of line. Standard lines are stocked in increments of 1m lengths, but custom hoses are available to assist in optimizing brake line design.
- Routing lines can be done in other ways, using T-pieces or similar line splitters. This can be at the discretion of the installer, but the rule of thumb is that less line and fewer bleed points in one line is better.

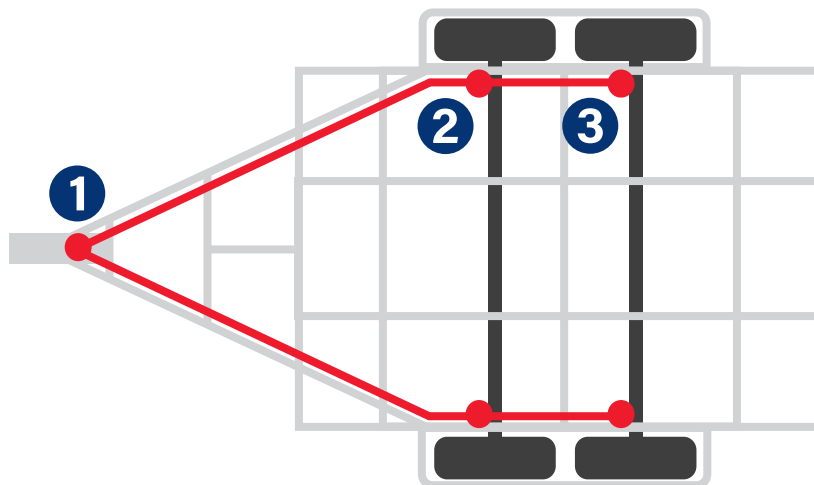

Trailparts recommend fitting a hose to each side of the trailer directly from the master cylinder using a double banjo bolt.



Run the brake line from the master cylinder into the front caliper along with the next hose to the rear caliper/brake using a double banjo bolt.



Run the line from the front brake to the rear one, and close the circuit using a single banjo bolt.

Note: Run lines into the bottom port in the caliper, leaving the bleed screw at the top.

BRAKE BLEEDING

If available, we recommend bleeding the brakes with an automotive style vacuum bleeder. If not, a bleeding slot is provided in the side of each Hygo MkII coupling. This allows the insertion of a standard large screwdriver or similar tool, which can then be used to pump the master cylinder to distribute fluid throughout the system.

The process of bleeding brakes will vary according to how the brakelines are installed. As a guide, follow this process;

1. Fill the system with Dot 3 or 4 brake fluid.
2. Before bleeding begins, begin with the reversing solenoid, and release any air from that internal circuit by activating it 3-4 times.
3. Pump or pull fluid through each bleed point, eliminating air bubbles before moving to the next.
 - **TIP:** *tapping the caliper or brake with a hammer can assist with the movement of air bubbles significantly.*
 - **TIP:** *elevating the brakes above the level of the master cylinder will help the flow of air bubbles to the bleeding point.*
4. Close each bleed port securely as it is finished



TIP: *Trailparts stock a range of accessories to assist in the running of brake lines.*



BRAKE CABLE INSTALLATION

The Hygo MkII system requires a mechanical parking brake. This can be used to securely park the trailer, but importantly, it doubles as the emergency brake function which will apply the trailer brakes if the trailer separates from the towing vehicle.

HYGO MKII - HYDRAULIC DRUM BRAKES

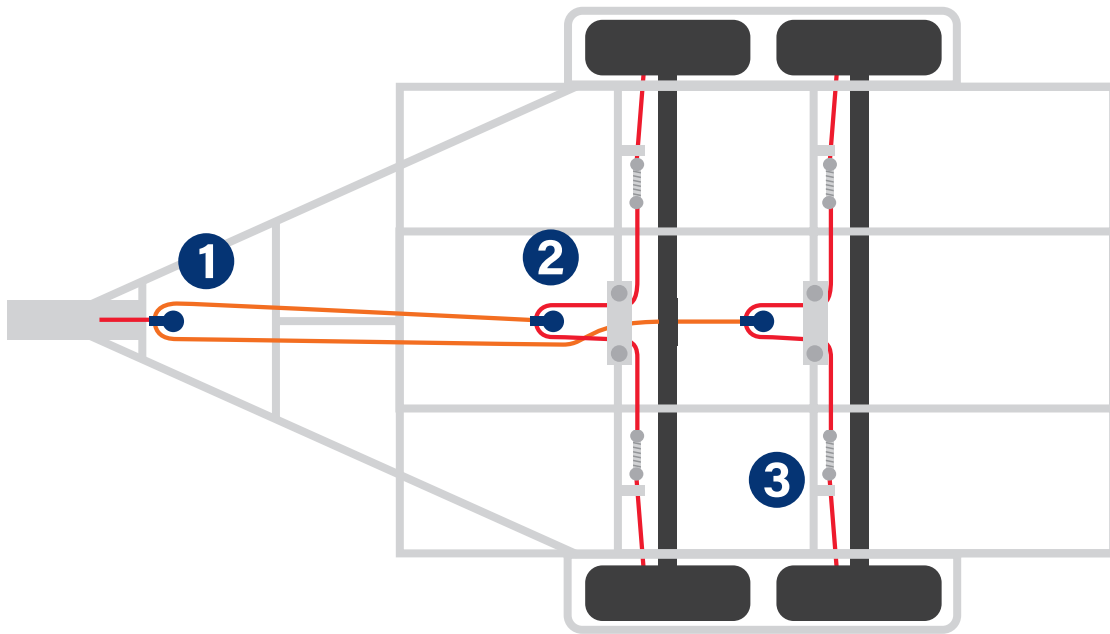

Hygo MkII drum braked axles are supplied fitted with a Bowden cable fitted to facilitate installation. While cables from these to the coupling-mounted brake lever can be run in different ways successfully, Trailparts recommends the centre pull routing and setup as shown in diagram above.

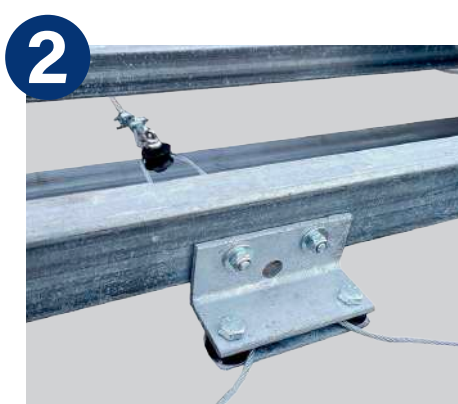
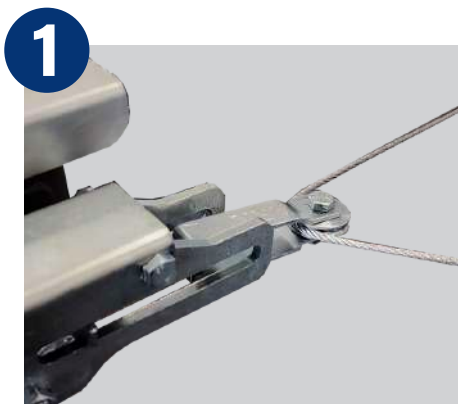

BRAKE CABLE INSTALLATION - CONT.

Manufacturers may wish to route cables pulling forward. This is an acceptable solution, but in order to comply with the requirements in the Hygo MkII certification, these three features following must be fitted;

1. Tension Spring:

- A tension spring (supplied) is fitted to the cable in front of the Bowden cable at each brake. This ensures that the handbrake always has the correct tension throughout its life. It must be within the first loop described in the following;

2. Equalizing Left/Right:

- Each brake cable must have equal cable tension on it. This can be achieved by routing the cable in a loop between the left and right drum on each axle, then adding a pulley as an equalizer to the loop, which can then be pulled forward.

Note: Each cable loop must be formed with two cable clamps.

3. Equalizing Front/Back:

- The front and back axles are then equalised. Run a cable from each axle equalizing pulley going in a loop around a third pulley again at the coupling.

Note: Each cable loop must be formed with two cable clamps.

Adjusting the Hygo II Drum Brake cable system

Cables should be relaxed without being slack. When the system is complete and the handbrake is applied, an indication of correct cable tension is that the tension springs at each wheel should have elongated by 10mm over the closed length.

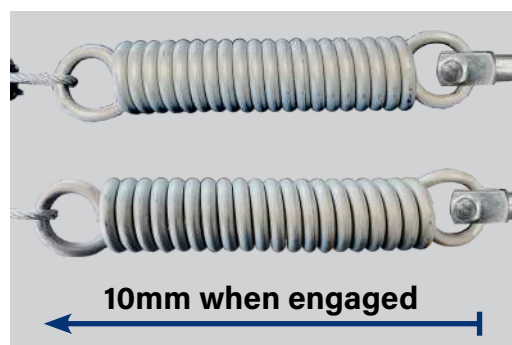
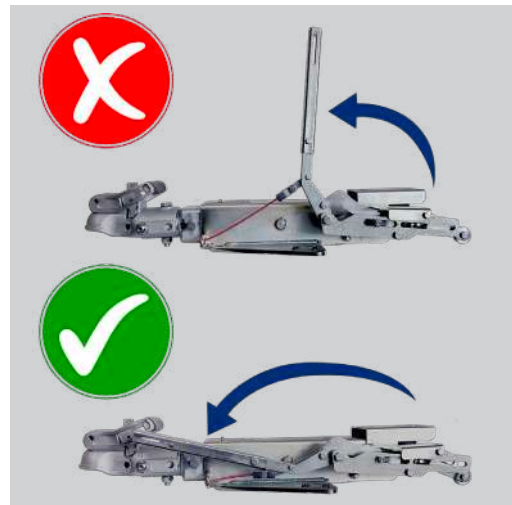

FINAL CHECKS

- ✓ Check coupling mount bolts are torqued to specifications.
- ✓ Ensure brake lines are free of kinks or chafing points, and are securely mounted.
- ✓ Check cables will pull freely, and that the handbrake applies firmly and with the tension spring elongated by 10mm. *(When engaging handbrake, lever should be pulled to its full limit in a horizontal position)*

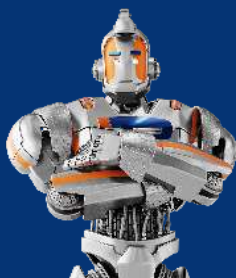

BRAKE CABLE INSTALLATION

The Hygo MkII system requires a mechanical parking brake. This can be used to securely park the trailer, but importantly, it doubles as the emergency brake function which will apply the trailer brakes if the trailer separates from the towing vehicle.

HYGO MKII - PATRIOT DISC BRAKES

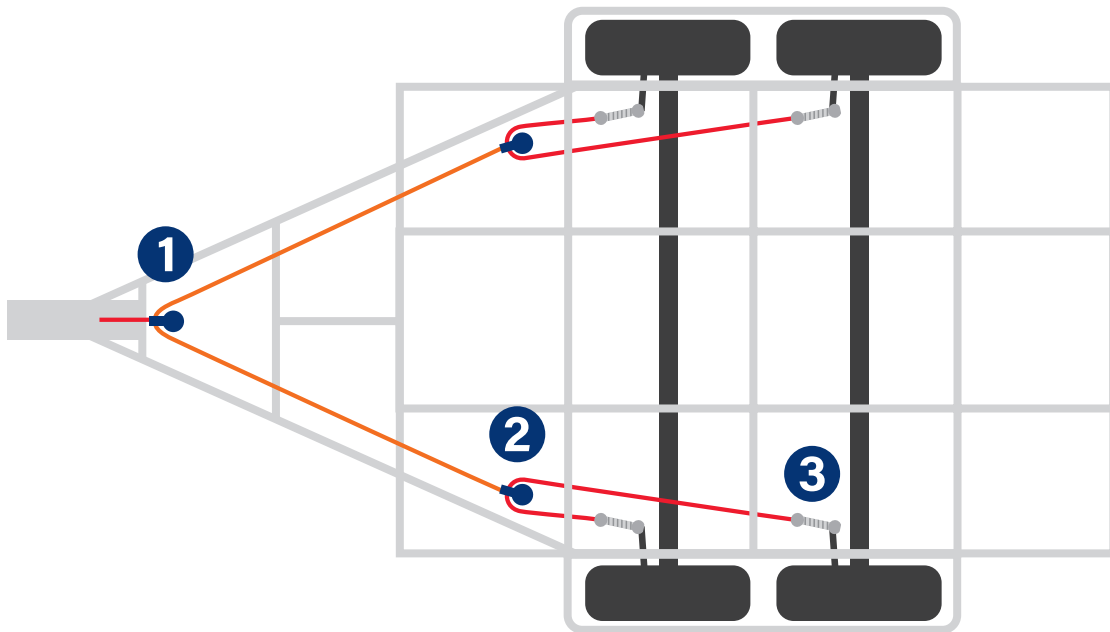

Patriot disc braked axles require a forward pull cable configuration, as shown in the diagram following. On axles built by Trailparts, the caliper is mounted at about the 10 o'clock / 2 o'clock position so that the handbrake lever is angling up and towards the chassis for easier routing.

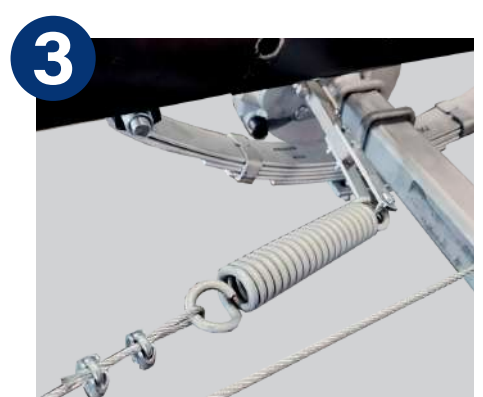
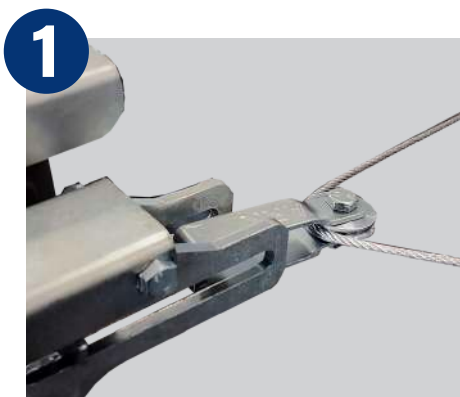

BRAKE CABLE INSTALLATION - CONT.

Each braked wheel must be equalized to the others, as follows;

1. Tension Spring:

- A tension spring (supplied) is fitted to the cable from each brake, and we recommend fixing this directly to the brake lever. This ensures that the handbrake always has the correct tension throughout its life.

2. Equalizing Front/Back:

- Each brake lever must have equal cable tension on it, which can be achieved by routing the cable in a loop between the front and rear axle, then adding a pulley as an equalizer to the loop, which can then be pulled forward. One for the left hubs and one for the right.

Note: Each cable loop must be formed with two cable clamps.

3. Equalizing Left/Right:

- The whole cable brake system is equalized together by running a loop from each side's equalizing pulley forward and through the adjuster pulley located at the coupling.

Note: Each cable loop must be formed with two cable clamps.

Adjusting the Hygo MkII Patriot Disc Brake cable system

Cables need to be relaxed enough so that suspension movement when loaded does not cause them to engage. When the system is complete and the handbrake is applied, an indication of correct cable tension is that the tension springs at each wheel should have elongated by 10mm over the closed length.

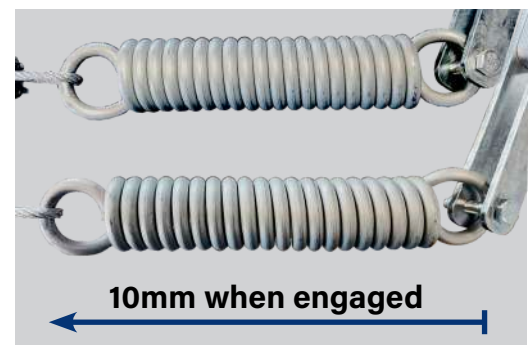
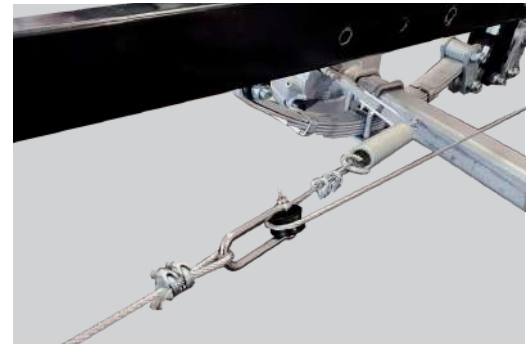
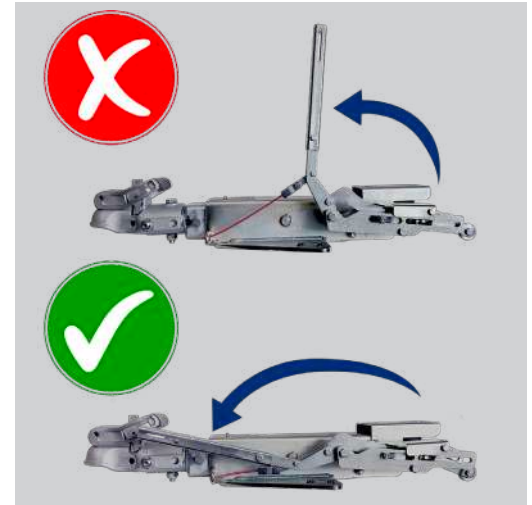

FINAL CHECKS

- ☑ Check coupling mount bolts are torqued to specifications.
- ☑ Ensure brake lines are free of kinks or chafing points, and are securely mounted.
- ☑ Check cables will pull freely, and that the handbrake applies firmly and with the tension spring elongated by 10mm. (When engaging handbrake, lever should be pulled to its full limit in a horizontal position)



HYGO MKII COUPLING OPERATION

PARK BRAKE

Trailparts Hygo MkII is using an over center handbrake lever.

- When manually engaging the hand brake. Ensure the lever arm is pulled forward until it reaches its limit. The arm should be in a horizontal.

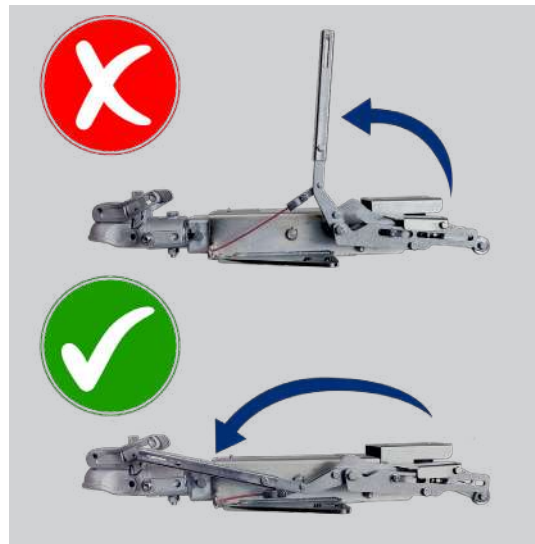

REVERSING LOCK OUT

Use as required for servicing, or if reverse solenoid is not servicable.

- To manually engage reversing lock out, Flip the lever to the forward position (Toward the table as shown in image).

Note: The brakes will not engage during general forward towing when the reverse lock out is left in this position.



BREAKAWAY LANYARD

A stand-alone cable brake system provides a parkbrake function that doubles as an emergency brake that activates in the event of a tow vehicle separation.

- Always insure the lanyard is attached to the tow vehicle in place of the safety chain.



BRAKE TEST / BLEED ACCESS

Through square hole located above 'Reversing Lockout'. Reach a flathead screwdriver inside to lever the master cylinder actuator yoke. This can be used to manually engage the brakes for testing and/or while pumping the actuator during brake line bleed process.

